

Write your name here

Surname

Other names

Centre Number

Candidate Number

Edexcel GCSE

Physics/Additional Science

Unit 2: Physics for Your Future

Higher Tier

Thursday 7 March 2013 – Morning

Time: 1 hour

Paper Reference

5PH2H/01

You must have:

Calculator, ruler

Total Marks

Instructions

- Use **black** ink or ball-point pen.
- **Fill in the boxes** at the top of this page with your name, centre number and candidate number.
- Answer **all** questions.
- Answer the questions in the spaces provided
– *there may be more space than you need.*

Information

- The total mark for this paper is 60.
- The marks for **each** question are shown in brackets
– *use this as a guide as to how much time to spend on each question.*
- Questions labelled with an **asterisk** (*) are ones where the quality of your written communication will be assessed
– *you should take particular care with your spelling, punctuation and grammar, as well as the clarity of expression, on these questions.*

Advice

- Read each question carefully before you start to answer it.
- Keep an eye on the time.
- Try to answer every question.
- Check your answers if you have time at the end.

Turn over ►

P41961A

©2013 Pearson Education Ltd.

1/1/1/1/



PEARSON

FORMULAE

You may find the following formulae useful.

charge = current \times time

$$Q = I \times t$$

potential difference = current \times resistance

$$V = I \times R$$

electrical power = current \times potential difference

$$P = I \times V$$

energy transferred = current \times potential difference \times time

$$E = I \times V \times t$$

$$\text{speed} = \frac{\text{distance}}{\text{time}}$$

$$\text{acceleration} = \frac{\text{change in velocity}}{\text{time taken}}$$

$$a = \frac{(v - u)}{t}$$

force = mass \times acceleration

$$F = m \times a$$

weight = mass \times gravitational field strength

$$W = m \times g$$

momentum = mass \times velocity

$$P = m \times v$$

$$\text{force} = \frac{\text{change in momentum}}{\text{time}}$$

$$F = \frac{(mv - mu)}{t}$$

work done = force \times distance moved in the direction of the force

$$E = F \times d$$

$$\text{power} = \frac{\text{work done}}{\text{time taken}}$$

$$P = \frac{E}{t}$$

gravitational potential energy = mass \times gravitational field strength \times vertical height

$$\text{GPE} = m \times g \times h$$

kinetic energy = $\frac{1}{2} \times$ mass \times velocity²

$$\text{KE} = \frac{1}{2} \times m \times v^2$$



BLANK PAGE

Questions begin on next page



Answer ALL questions.

Some questions must be answered with a cross in a box . If you change your mind about an answer, put a line through the box and then mark your new answer with a cross .

Charge and Current

1 A battery sends a current through a metal wire.

(a) (i) Complete the sentence by putting a cross () in the box next to your answer.

Direct current is movement of charge

(1)

- A** backwards and forwards
- B** in many directions
- C** in one direction
- D** up and down

(ii) Complete the sentence by putting a cross () in the box next to your answer.

The particles that flow in the metal wire are

(1)

- A** atoms
- B** electrons
- C** protons
- D** neutrons

(b) The current in a wire is 3.7 A.

Calculate the charge that flows into the wire in 13 s.

(2)

charge = C



(c) Plastic is an insulator.

A student rubs a piece of plastic with a cloth.

This gives the plastic a negative charge.

(i) Explain how the plastic is charged by the rubbing.

(2)

.....

.....

.....

.....

(ii) The cloth is also charged when it rubs against the plastic.

Describe the charge on the cloth.

(2)

.....

.....

.....

.....

(Total for Question 1 = 8 marks)



Going downhill

2 Andrew skis down a hill.



(a) Andrew starts from the top of the hill and his speed increases as he goes downhill.

He controls his speed and direction by using his skis.

He brings himself to a stop at the bottom of the hill.

Describe the energy changes that happen between starting and stopping.

(3)

.....

.....

.....

.....

.....

.....



(b) Andrew returns to the top of the hill and starts again.

(i) His mass is 67 kg.

Show that his momentum is about 2000 kg m/s when his velocity is 31 m/s. (2)

(ii) He falls over when his momentum is 2000 kg m/s.

After he falls over, he slows down by sliding across the snow.

It takes 2.3 s for his momentum to reduce to zero.

Calculate the average force on Andrew as he slows down. (2)

force = N

(iii) Andrew is not injured by the fall even though he was moving quickly.

Use ideas about force and momentum to explain why he is not injured. (2)

.....

.....

.....

.....

(Total for Question 2 = 9 marks)



Motion and Forces

3 The graph shows how the velocity of a small car changes with time.

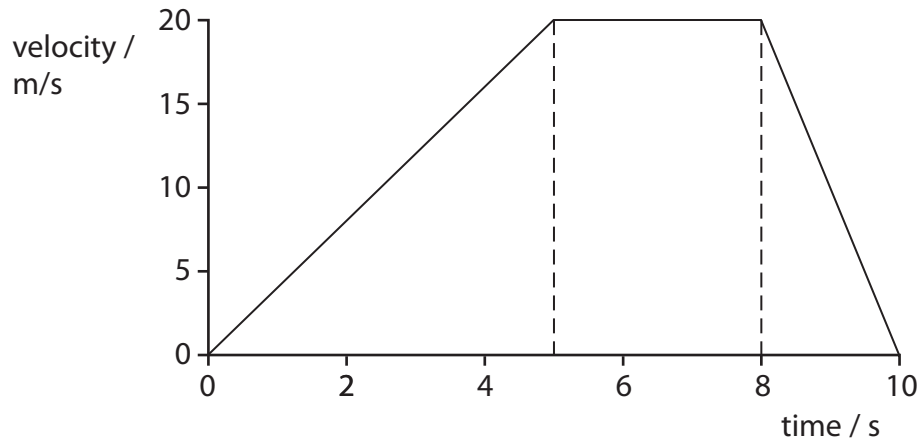

(a) Complete the sentence by putting a cross (☒) in the box next to your answer.

The resultant force on the car will be zero when the car is

(1)

- A accelerating
- B decelerating
- C changing velocity
- D moving at a constant velocity

(b) (i) Use the graph to estimate the velocity of the car at three seconds.

(1)

velocity m/s



(ii) Calculate the acceleration of the car when it is speeding up.

(2)

acceleration = m/s²

(iii) Explain why the units of acceleration are m/s².

(2)

.....

.....

.....

.....

(iv) Show that the car travels further at a constant velocity than it does when it is slowing down.

(3)

(Total for Question 3 = 9 marks)



Carbon dating

4 Carbon-14 is a radioactive isotope that occurs naturally.

Scientists use carbon-14 to help find the age of old pieces of wood.

This technique is called carbon dating.

It uses the idea of half-life.

(a) Which of these describes half-life?

Put a cross (☒) in the box next to your answer.

(1)

- A** the time it takes for half of the undecayed nuclei to decay
- B** the time it takes for all of the undecayed nuclei to decay
- C** half the time it takes for all of the undecayed nuclei to decay
- D** half the time it takes for half of the undecayed nuclei to decay

(b) Sketch a graph to show how the activity of a radioactive isotope changes with time.

Use the axes below. Start your line from point P.

(3)

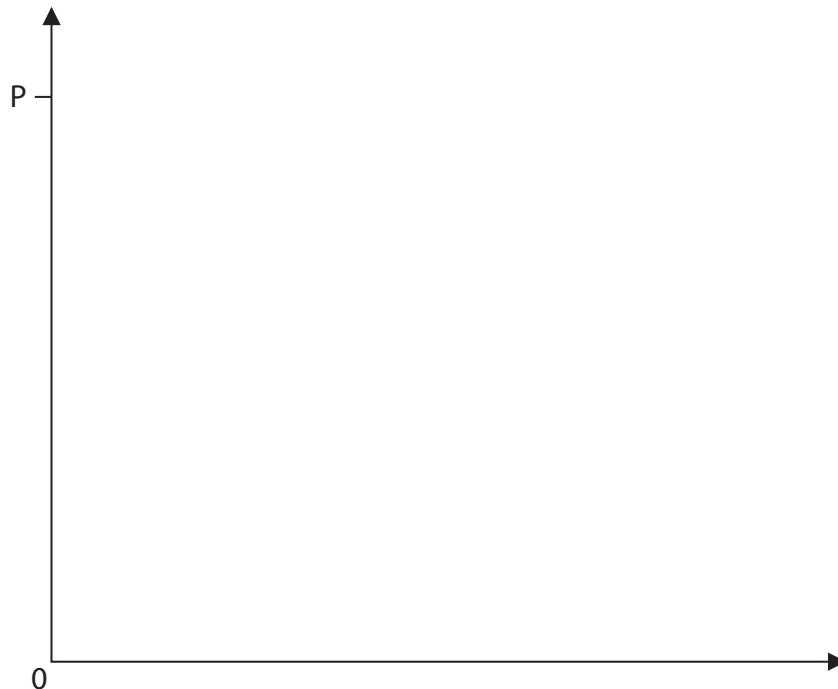

(c) A scientist investigates an old wooden comb.

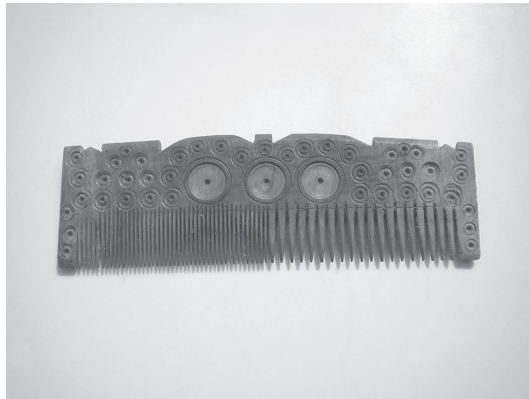

The activity of the carbon-14 in it is 0.55 Bq.

The estimated age of the comb is 11 400 years.

The half-life of carbon-14 is 5700 years.

(i) Calculate the activity of the carbon-14 in the comb when it was new.

(3)

activity = Bq

(ii) The scientist takes several readings of background radiation.

Explain why this is necessary to improve the accuracy of the investigation.

(2)

.....

.....

.....

.....

.....



(iii) Old objects like the comb emit a very small amount of radiation.

The activity from the comb is about the same as comes from background radiation.

Scientists have stopped measuring the activity of carbon-14 for carbon dating.

Instead, they can measure the mass of undecayed carbon-14 left in the sample.

Suggest a reason for this change.

(1)

.....

.....

.....

(Total for Question 4 = 10 marks)



BLANK PAGE



Electric circuits

5 (a) The diagram shows an electric circuit with two resistors, R and S.

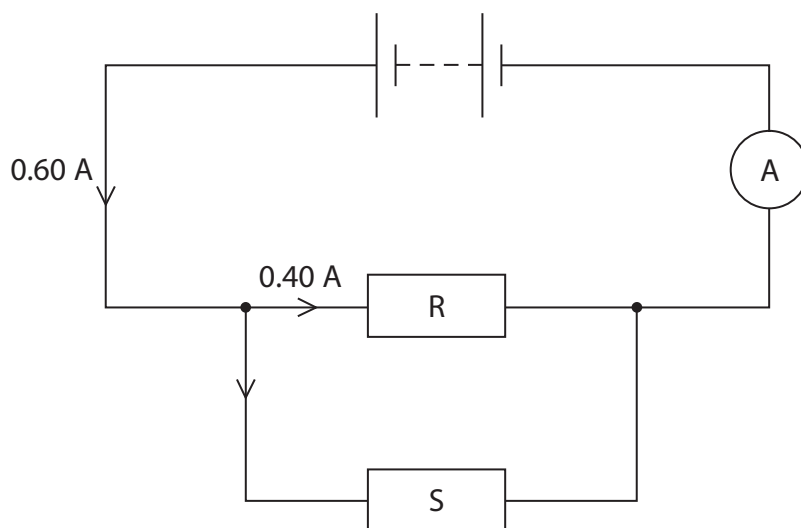

(i) R has a resistance of 11 ohms.

Calculate the potential difference across R.

(2)

potential difference = V



(ii) Use information from the diagram to calculate the current in S.

(1)

current = A

(iii) Complete the sentence by putting a cross (☒) in the box next to your answer.

A student wants to measure the battery voltage with a voltmeter.

The voltmeter should be placed

(1)

- A** in series with the battery
- B** in parallel with the battery
- C** in parallel with the ammeter
- D** in series with either resistor R or S

(b) Explain why the temperature of a resistor increases when a current passes through it.

(2)

.....

.....

.....

.....



Ionising radiation

6 Alpha, beta and gamma are types of ionising radiation.

(a) State **two** ways in which gamma radiation is different from alpha radiation.

(2)

.....

.....

.....

.....

(b) (i) Complete the sentence by putting a cross (☒) in the box next to your answer.

A beta particle is emitted by

(1)

- A an alpha particle
- B a fusion particle
- C a gamma ray
- D an unstable nucleus

(ii) Complete the sentence by putting a cross (☒) in the box next to your answer.

A beta particle has an identical charge to

(1)

- A an alpha particle
- B an electron
- C a neutron
- D a nucleus

(c) Explain how an atom becomes ionised by radiation.

(2)

.....

.....

.....

.....



*(d) The removable lens of this old camera has four pieces of glass in it.

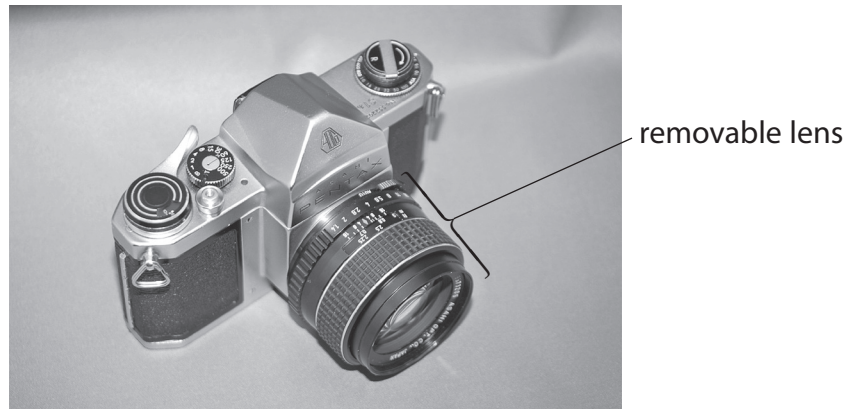

One of the pieces of glass is radioactive. Its surface is covered with a thin layer of magnesium fluoride.

Radioactive isotopes in the glass emit alpha, beta and gamma radiation in all directions.

A scientist removes the lens from the camera. She measures the radiation coming from the back, front and side of the lens.

The amount of radiation is different in each direction.

No alpha radiation is detected.

The readings are shown on the diagram.

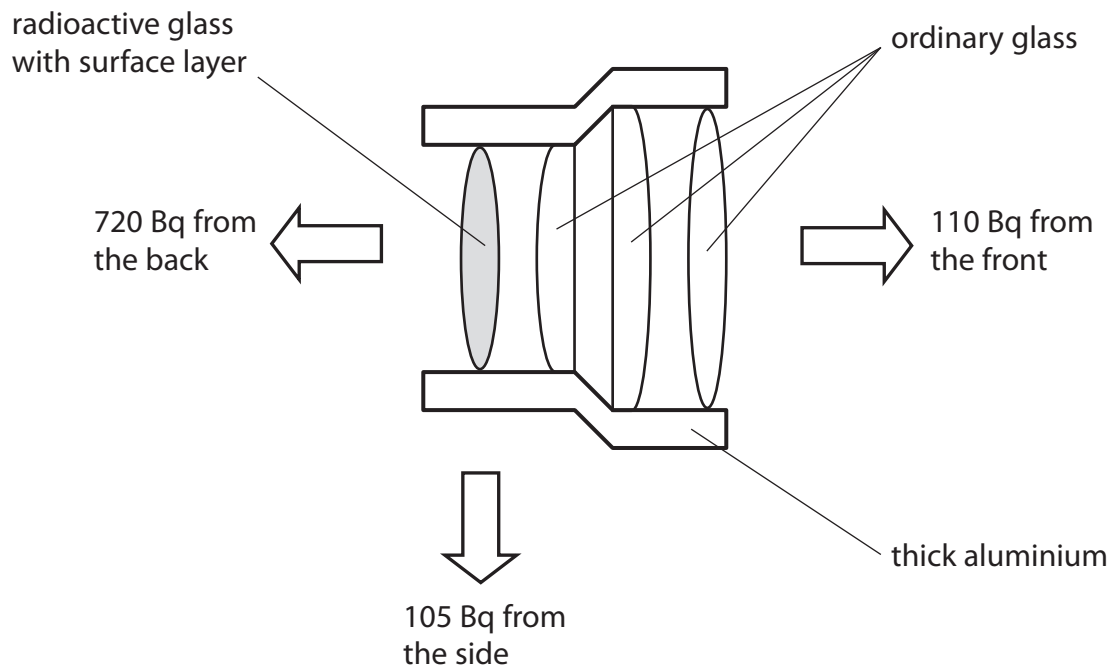

Explain why the readings in the three directions are different.

(6)

Area with horizontal dotted lines for writing the answer.

(Total for Question 6 = 12 marks)

TOTAL FOR PAPER = 60 MARKS



BLANK PAGE

